



An Approach to SIR Epidemic Model using Markovian Retrial Queues

Elizabeth Sebastian^{1*} and Priyanka Victor²

^{1,2}Auxilium College (Autonomous), Vellore - 632 006, Tamil Nadu, India.

Abstract

In this paper, we construct a SIR model and analyse it through queueing theory techniques. We study the model on an individual level. We formulate a SIR epidemic model using Markovian retrial queue. We intend to find the stability of the model. We have derived the generating function of the model. We have also derived the stationary distribution of the model, explicit formulae and the recursive formulae. We have analysed the stochastic decomposition property and have obtained a stability condition for the model.

Key words: Difference equations, Retrial queues, Stationary distribution, Stochastic decomposition.

AMS classification: 39A10, 60K25, 60J20.

1. Introduction

Queueing theory is concerned with the mathematical techniques for analysing the flow of objects through some network. The network contains one or more locations at which there is some restriction on the times or frequencies at which the object can pass. The objects could be anything which move from place to place, people, cars, water, money, jobs to be done etc. One could consider all sorts of networks [10].

We apply the queueing theory to epidemic models. We use the concept of retrial queues to construct an SIR epidemic model. Almost all the events in the society follow queueing patterns. We either provide service or get service. Epidemiology can be formulated in terms of queueing theory as the infectives infect the susceptible population in a queueing archetype. By modelling epidemic models in queueing theory, we get a more intricate look on how the system works and hence can solve the model in a more accurate manner [9].

Very few literatures have been found in queueing theory applied to epidemic models. Queueing Technique for Ebola Virus Disease Transmission and Control Analysis was studied by Chinyere Ogochukwu Dike, Zaitul Marlizawati Zainuddin and Ikeme John

^{1*}elizafma@gmail.com, ²priyankavictor2@gmail.com

Dike. They applied $M/M/1$ queue to ebola epidemic[4]. Okoro Otonritse Joshua studied the markovian queueing model and applied them to epidemic models[5]. In this paper, we formulate the SIR epidemic model using Markovian retrial queues and analyse the model. Elizabeth Sebastian and Priyanka Victor studied the SIS epidemic model using Markovian retrial queues [9].

2. Model Description

We consider a single server retrial queue. Here we consider that the infected individual takes the place of a server in the system. If an individual is susceptible, he goes to state 0, if he gets infected, he reaches to state 1 and when he is recovered, he goes to state 2. Here we assume that the server can make contact with only one individual at a time t . μ is the rate at which the recovered individual is infected again. λ_1 is the rate at which susceptible individual gets infected. λ_2 is the rate at which infected individual gets recovered. Incoming individuals, those who are susceptible to the infection approach the infective(server) according to a poisson process with a rate θ . But these susceptible individuals find the infective(server) busy, that is either the infective is recovered or remains infected, will remain susceptible and may get infected in a random manner (repeat the approach in a random manner).

The susceptibles individuals those who come into contact with infective, they remain in the orbit. Those individuals from the orbit get infected at a rate $j\gamma$. In this model, we consider a single infective and N susceptibles and hence it is a $M/M/1/N$ Markovian model.

3. Transition Diagram and Balance Equations

The Compartmental SIR Epidemic model is given below:

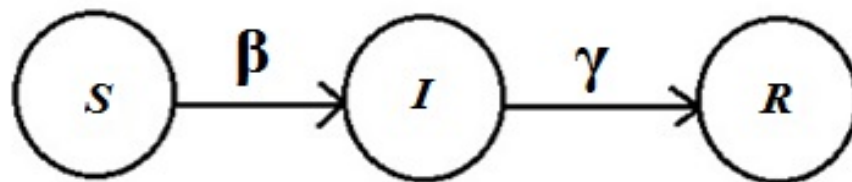

Figure 1: SIR Epidemic model

In figure 1, there are three compartments namely the susceptible population S and the infected population I and recovered population R . β is the infection rate and γ is the recovery rate. In the compartmental model the susceptible, infected and recovered are considered as a group of population.

¹*eliazafma@gmail.com, ²priyankavictor2@gmail.com

Our aim is to provide a closer and clear look at this epidemic model and hence make use of queuing theory. Instead of considering as a group of population, we consider the individuals. This might provide an easy and realistic approach to epidemic modelling. Let $I(t)$ denote the state of the infective(server), that is, an individual at time $t \geq 0$.

$$I(t) = \left\{ \begin{array}{ll} 0 & \text{the individual is susceptible} \\ 1 & \text{the individual is infected} \\ 2 & \text{the individual is recovered} \end{array} \right\} \quad (1)$$

Let $N(t)$ denote the number of incoming susceptible individuals remaining in the orbit at time t [1],[2],[3].

We see that, $X(t) = (I(t), N(t)); t \geq 0$.

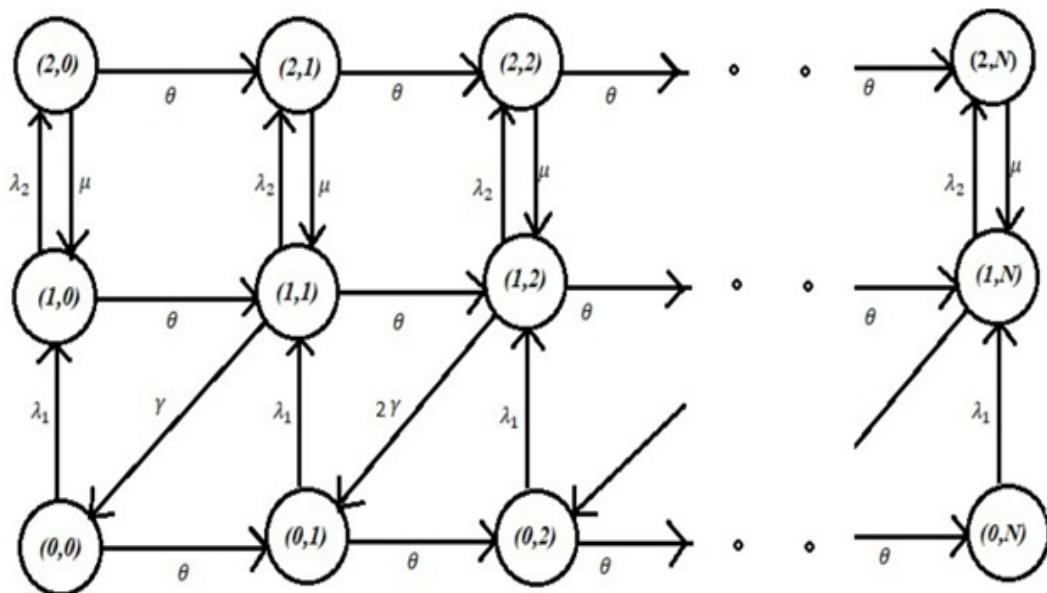

Figure 2: Transition diagram of SIR Epidemic Model

We assume that the Markov chain is ergodic.

$$\pi_{i,j} = \lim_{t \rightarrow \infty} P(I(t) = i, N(t) = j), \quad i = 0, 1, 2, 3, \dots \quad j \in Z_+$$

It follows from the figure that the system of balance equations for $\pi_{i,j}$ is given by the following difference equations [8].

¹*eliazfma@gmail.com, ²priyankavictor2@gmail.com

$$(\lambda_1 + \theta) \pi_{0,j} = (j + 1)\gamma\pi_{1,j+1} + \theta\pi_{0,j-1} \quad (2)$$

$$(\lambda_2 + \theta) \pi_{1,j} + j\gamma\pi_{1,j} = \mu\pi_{2,j} + \theta\pi_{1,j-1} + \lambda_1\pi_{0,j} \quad (3)$$

$$(\mu + \theta) \pi_{2,j} = \lambda_2\pi_{1,j} + \theta\pi_{2,j-1} \quad (4)$$

For $j \in Z_+$, where $\pi_{i,-1} = 0$ ($i = 0, 1$). Let $P_i(z)$ denote the partial generating function of $\pi_{i,j}$.

$$P_i(z) = \sum_{j=0}^{\infty} \pi_{i,j} z^j \quad i = 0, 1, \quad |z| \leq 1 \quad (5)$$

Multiplying the equations (2) and (3) and (4) by z^j and taking summation over j , we get

$$(\lambda_1 + \theta) P_0(z) = \gamma_1 P_1'(z) + \theta z P_0(z) \quad (6)$$

$$(\lambda_2 + \theta) P_1(z) + \gamma_1 z P_1'(z) = \mu P_2(z) + \theta z P_1(z) + \lambda_1 P_0(z) \quad (7)$$

$$(\mu + \theta) P_2(z) = \lambda_2 P_1(z) + \theta z P_2(z) \quad (8)$$

Summing the above three equations, we get

$$\gamma_1 P_1'(z) = \theta [P_0(z) + P_1(z) + P_2(z)] \quad (9)$$

4. Stationary Distribution

In this section, we get the explicit expressions for the joint stationary distribution through generating functions.

Generating Function

Theorem 4.1 The explicit expressions of the partial generating functions for $|z| \leq 1$ are given as follows:

$$P_0(z) = P_1(z) \left[\frac{\theta(\lambda_2 + \theta(1 - z) + \mu)}{(\theta(1 - z) + \mu)(\lambda_1 - \theta z)} \right] \quad (10)$$

$$P_2(z) = P_1(z) \left[\frac{\lambda_2}{(\theta(1 - z) + \mu)} \right] \quad (11)$$

$$P_1(z) = P_1(1) \left[e^{\frac{\theta D_1}{\gamma_1}(z-1)} \left(\frac{\lambda_1 - \theta}{\lambda_1 - \theta z} \right)^{\frac{\theta D_1}{\gamma_1}} \right] \quad (12)$$

Where $\rho = \frac{\theta}{\lambda_1}$, $D_1 = 1 + C_1$, $D_2 = C_2(1 + C_1)$

Proof: Substituting (9) in (6), we obtain

$$P_0(z) (\lambda_1 - \theta z) = \theta [P_1(z) + P_2(z)] \quad (13)$$

Substituting (9) in (7), we obtain

$$P_0(z) (\lambda_1 - \theta z) = (z\theta - \mu) P_2(z) + (\theta + \lambda_2) P_1(z) \quad (14)$$

From the above two equations we get

$$P_2(z) = \frac{\lambda_2}{(\theta(1-z) + \mu)} P_1(z) \quad (15)$$

Substituting (15) in (9)

$$\gamma_1 P_1'(z) = \theta \left[P_0(z) + P_1(z) \left(\frac{\lambda_2 + \theta(1-z) + \mu}{\theta(1-z) + \mu} \right) \right] \quad (16)$$

Substitute (16) in (1)

$$P_0(z) = \frac{\theta (\lambda_2 + \theta(1-z) + \mu)}{(\theta(1-z) + \mu)(\lambda_1 - \theta z)} \quad (17)$$

Substitute (17) in (16)

$$\gamma_1 \frac{P_1'(z)}{P_1(z)} = \left[\frac{\lambda_2 + \theta(1-z) + \mu}{\theta(1-z) + \mu} \right] \left[\frac{\theta + \lambda_1 - \theta z}{\lambda_1 - \theta z} \right] \quad (18)$$

Integrating on both sides, we get

$$[\log P_1(z)]_1^z = \frac{\theta}{\gamma_1} (1 + C_1)(z - 1) + \frac{C_2(1 + C_1)}{\gamma_1} \left[\log \frac{\lambda_1 - \theta}{\lambda_1 - \theta z} \right] \quad (19)$$

From this, we get

$$P_1(z) = P_1(1) \left[e^{\frac{\theta D_1}{\gamma_1}(z-1)} \left(\frac{\lambda_1 - \theta}{\lambda_1 - \theta z} \right)^{\frac{\theta D_1}{\gamma_1}} \right]$$

$$P_2(z) = P_1(z) \left[\frac{\lambda_2}{(\theta(1-z) + \mu)} \right]$$

$$P_0(z) = P_1(z) \left[\frac{\theta (\lambda_2 + \theta(1-z) + \mu)}{(\theta(1-z) + \mu) (\lambda_1 - \theta z)} \right]$$

Consider the following normalizing condition

$$P_0(1) + P_1(1) + P_2(1) = 1 \quad (20)$$

We obtain

$$P_1(1) \left[\frac{\theta}{\mu} \left(\frac{\lambda_2 + \mu}{\lambda_1 - \theta} \right) + 1 + \frac{\lambda_2}{\mu} \right] = 1 \quad (21)$$

which implies

$$P_1(1) \left[\frac{1 + \eta}{1 - \rho} \right] = 1 \quad (22)$$

where $\eta = \frac{\lambda_2}{\mu}$. We get $P_1(1) = \frac{1-\rho}{1+\eta}$, $P_2(1) = \eta \left[\frac{1-\rho}{1+\eta} \right]$, $P_0(1) = \rho$.

Corollary 4.2 The equation (22) implies that the necessary and sufficient condition for the stability of the system is given by $\rho < 1$.

Explicit Expressions

Theorem 4.3 The following are the explicit expressions for the stationary distribution

$$\pi_{0,j} = \pi_{1,j} \rho \frac{1 + \eta}{1 - \rho} \quad (23)$$

$$\pi_{1,j} = \pi_{1,0} \left[\sum_{k=0}^j \frac{(\frac{\theta D_1 z}{\gamma})^k}{k!} \left(\frac{D_2}{\gamma} \right)^{j-k} \frac{\rho^{j-k}}{(j-k)!} \right] \quad (24)$$

$$\pi_{2,j} = \pi_{1,j} \eta \quad (25)$$

for $j \in Z_+$.

Proof: From (12) we have,

$$P_1(z) = \frac{1 - \rho}{1 + \eta} \left[e^{\frac{\theta D_1}{\gamma_1}(z-1)} \left(\frac{\lambda_1 - \theta}{\lambda_1 - \theta z} \right)^{\frac{\theta D_1}{\gamma_1}} \right] \quad (26)$$

$$\sum_{j=0}^{\infty} \pi_{1,j} z^j = \pi_{1,0} \left[\sum_{j=0}^{\infty} \frac{(\frac{\theta D_1 z}{\gamma})^j}{j!} \sum_{j=0}^{\infty} \left(\frac{D_2}{\gamma} \right)_j \frac{(\rho z)^j}{j!} \right]$$

Whose inversion leads to (23).

Recursive Formulae

Theorem 4.4 We compute the stationary probabilities using the following recursive formulae

$$\begin{aligned}\pi_{0,j} &= \frac{\theta[\pi_{0,j-1} + \pi_{1,j} + \pi_{2,j}]}{\lambda_1} \\ \pi_{1,j} &= \frac{\theta[\pi_{0,j-1} + \pi_{1,j-1} + \pi_{2,j-1}]}{j\gamma} \\ \pi_{2,j} &= \frac{[\lambda_2\pi_{1,j} + \theta\pi_{2,j-1}]}{\mu + \theta}\end{aligned}$$

$\pi_{0,0}$ is given in theorem 1.

Proof: Summing the equations (2), (3) and (4), we get

$$\theta\pi_{0,j-1} - j\gamma\pi_{1,j} + \theta\pi_{1,j-1}\theta\pi_{2,j-1} = 0$$

From which we obtain

$$\pi_{1,j} = \frac{\theta[\pi_{0,j-1} + \pi_{1,j-1} + \pi_{2,j-1}]}{j\gamma}$$

Substituting the above equation in (3), we get

$$\begin{aligned}\pi_{0,j} &= \frac{\theta[\pi_{0,j-1} + \pi_{1,j} + \pi_{2,j}]}{\lambda_1} \\ \pi_{2,j} &= \frac{[\lambda_2\pi_{1,j} + \theta\pi_{2,j-1}]}{\mu + \theta}.\end{aligned}$$

5. Stochastic Decomposition

In this section, we consider the stochastic decomposition property for the number of incoming susceptible population in the system(both orbit and server). We show that the number of incoming individuals can be decomposed into two independent random variables.

Theorem 5.1 In steady state, we have

$$L(t) = L_C(t) + L_M(t)$$

where $L_C(t)$ denotes the number of incoming susceptible population in the system

¹*elizafma@gmail.com, ²priyankavictor2@gmail.com

at time t and $L_M(t)$ denote the number of incoming susceptible population when the infective is idle at time t .

6. Conclusion

In this paper, we have constructed an SIR epidemic model using Markovian single server retrieval queues. By means of the generating function approach, we have shown the stochastic decomposition property for the number of incoming susceptible individuals in the system. We have obtained a stability condition for the model. We have derived explicit formulae and recursive formulae for the joint stationary distribution of the number of repeated attempts and the state of the infective.

References

- [1] Agarwal RP, Difference Equations and Inequalities, New York: Marcel Dekker, (2000).
- [2] Saber Elaydi, An Introduction to Difference Equations , Third Edition, Springer, (2004).
- [3] David L Jagerman, Difference Equations with applications to queues, New York: Marcel Dekker, (2000).
- [4] Chinyere Ogochukwu Dike, Zaitul Marlizawati Zainuddin and Ikeme John Dike, Queueing Technique for Ebola Virus Disease Transmission and Control Analysis, In: Indian Journal of Science and Technology, 9, (2016).
- [5] Okoro Otonritse Joshua, On Markovian Queueing Model as Birth-Death Process, In: Global Journal of Science Frontier Research Mathematics and Decision Sciences, 13, 2013.
- [6] Artalejo JR, Lopez-Herrero MJ, The SIS and SIR stochastic epidemic models: A maximum entropy approach, In, Theoretical Population Biology, 80, 2011, 256-264.
- [7] Hiroyuki Sakurai, Tuan Phung-Duc, Single Server Markovian Retrieval Queues with Multiple Types of Outgoing Calls, QTNA 2013, (2013).
- [8] Falin GI, A Multiserver Retrieval Queue with a Finite Number of Sources of Primary Calls, Mathematical and Computer Modelling, 30, 1999, 33-49.
- [9] Elizabeth Sebastian and Priyanka Victor, A study on SIS Epidemic model using Markovian Retrieval queues, International Journal of Pure and Applied Mathematics, 117(11), 2017, 99-106.
- [10] Newell GF, Applications of queueing theory, New York, Chapman and Hall, (1982).